

承 认 书

SPECIFICATION FOR APPROVAL

用 户 CUSTOMER		部 品 名 称 PART NAME	HF-Choke
部 品 型 号 PART TYPE	TCC-JG3113-39uH	用 户 型 号 CUSTOMER NO	

1, 外形尺寸 OUTSIDE DIMENSION UNIT:mm

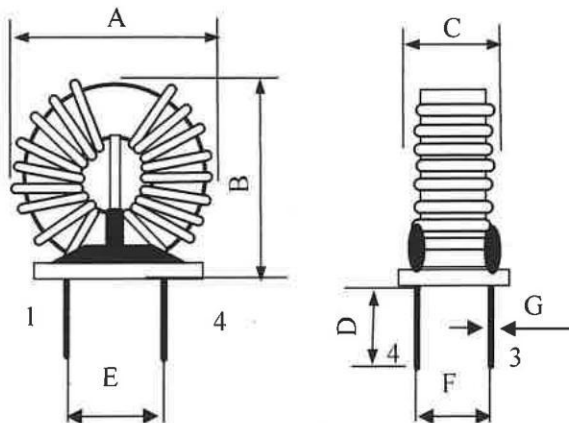

A:41.5max B: 38.7max C:21.4max D:3.5±0.5 E:22.5±0.5 F:13.5±0.5 G:Φ2.0

2,电路图 CURCUIT DIAGRAM

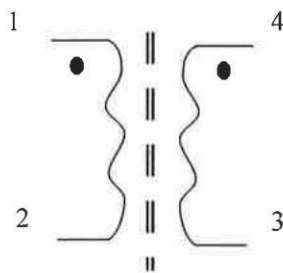

URNS RATIO: $\phi 2.0 \times 9T$ (Ref)

Winding(1-2): winding(3-4)=1: 1

DRAWN BY		REMARK	PAGE
CHECKED BY		版 本: A	2/3
APPROVED BY		Version: A	

常州市南方电器元件厂有限公司

CHANGZHOU SOUTHERN ELECTRONIC ELEMENT FACTORY

承 认 书

SPECIFICATION FOR APPROVAL

用 户 CUSTOMER		部 品 名 称 PART NAME	HF-Choke
部 品 型 号 PART TYPE	TCC-JG3113-39uH	用 户 型 号 CUSTOMER NO	

3,电性能参数 Electrical Characteristics (T_a= 25°C If not specified)

NO.	项 目 ITEM	标 准 STANDARD	测 试 条 件 Test Conditions	INFO
3-1	电感值 Inductance	L1 L2: 39uH±35%	F=100KHz	TH2816B
3-2	直流铜阻 DC Resistance	R ₁ R ₂ =2.73mΩ typ		TH2511
3-3	额定电流 Rated Current	I=20A	ΔT≤40°C	
3-4	耐压 HI-POT	AC2000V/5mA/2S (between N1、N2)	50Hz	DF2670A

4,Environment

Operating temperature : -40°C to +125°C

5,材料明细表 Material List

NO.	名 称 ITEM	材 料 MATERIAL	制 造 厂 商 MANUFACTURE	UL 证书号 ULFILE NO.
5-1	磁环 Core	FN40 T31X19X13	科峰 KEFENG	
5-2	漆包线 Copper wire	QZY/φ 2.0mm	山东赛特电工股份有限公司 SHANDONG SAINT ELECTRIC CO.,LTD	E194410
5-3	骨架 Bobbin	Φ31 磁环外壳 白色 PBT	古城 Gu Cheng	E171666
5-4	基板 Base	30×20.5×1.5 FR-4	南通运丰	
5-5	环氧胶 Epoxy	3300A/B	苏州力多	E253983



6,备注 INFO 本产品符合欧共体 ROHS 要求:

DRAWN BY		REMARK	PAGE
CHECKED BY		版 本: A	3/3
APPROVED BY		Version: A	

常州市南方电器元件厂有限公司

CHANGZHOU SOUTHERN ELECTRONIC ELEMENT FACTORY CO.LTD